

BL20 Economy Module
8 Digital Outputs
BL20-E-8DO-24VDC-0,5A-P

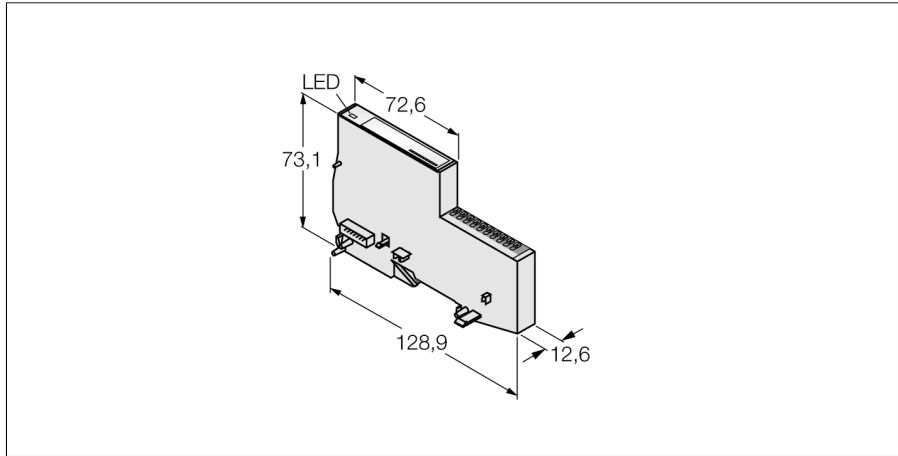

- Fieldbus-independent
- Electronics and connection technology in one housing
- Connectivity: Push-in terminals
- Protection class IP20
- 8 digital outputs, 24 VDC, max. 0.5 A, PNP switching

Functional principle

Electronics and connection technology are integrated in the housing. A base module is not needed. Economy modules and modules with separate electronics and connection technology can be fitted into a station, provided the base modules feature tension spring connections.

The use of gateways makes economy modules completely independent from the higher level fieldbus.

Type designation	BL20-E-8DO-24VDC-0,5A-P
Ident-No.	6827226
Number of channels	8
Rated voltage from the supply terminal	24 VDC
Admissible range	18...30 VDC
Nominal current from field supply	≤ 3 mA
Nominal current from module bus	≤ 15 mA
Power dissipation, typical	≤ 1.5 W
Output connectivity	Push-in
Output type	pnp
Output voltage	24 VDC
Output current per channel	0.5 A
Output delay	0.3 ms
Load type	resistive, inductive, lamp load
Load resistance, resistive	> 48 Ω
Lamp load	< 6 W
Switching frequency, resistive	< 100 Hz
Switching frequency, lamp load	< 10 Hz
Short-circuit protection	yes
Simultaneity factor	1
Electrical isolation	electronics for the field level
Dimensions (W x L x H)	12.6 x 128.6 x 74.6mm
Approvals	CE, cULus, zone 2, Class I, Div. 2
Operating temperature	0 to +55 °C
Storage temperature	-25...+85 °C
Relative humidity	5 to 95% (internal), Level RH-2, no condensation (at 45 °C storage)
Vibration test	acc. to EN 61131
Shock test	acc. to IEC 68-2-27
Drop and topple	acc. to IEC 68-2-31 and free fall to IEC 68-2-32
Electromagnetic compatibility	acc. to EN 50,082-2
Protection class	IP20

BL20 Economy Module
8 Digital Outputs
BL20-E-8DO-24VDC-0,5A-P

Terminal assignment

	<p>Digital Outputs</p>	<p>Pin Assignment</p> 
---	-------------------------------	--